

# Technical Data Sheet

Date: 03/11/2022

## 4x32A CEE N. Angled Panel Mount Socket

Ref. No: 3126-309-1600



Pack Unit

10



Weight

174 gr.



## Technical Informations

Ampere	32A
Voltage	380 - 415 V. AC
Hertz	50 - 60 Hz
Protection Class	IP 44
Clock Postion	6h
Number Of Poles	4 (3P + E)
Contact Material	Brass (CuZn)
Housing Material	PA6
Connection Type	Screw
Operation Temp.	-25 / +80 (1 hour -100° C)
	(-25 / + 40 IEC 60309)

## Dimensions

a	83	e	37
b	90	f	54
c	70	g	98
d	76	Øh	5
Cable Diameter (Min.)	2,5 mm <sup>2</sup>	k	66
Cable Diameter (Max.)	10 mm <sup>2</sup>	m	76

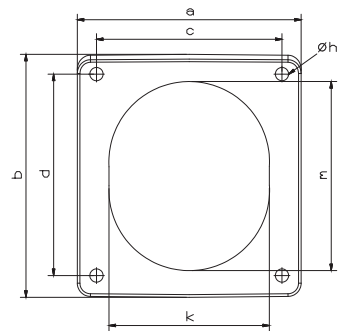
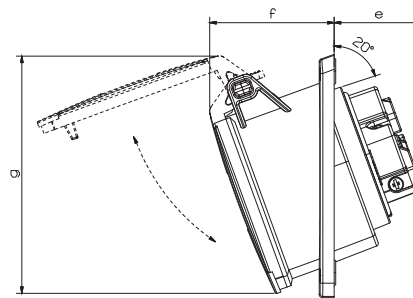

## Different Earth Contact Positions (Clock Positions)

3126-309-1100-2h	3126-309-1600-3h	3126-309-0700-4h	3126-309-0300-5h	3126-309-1600	3126-309-0300-7h	3126-309-0900-9h	3126-309-1100-10h	3126-309-1600-11h



Tel: +90 232 880 90 01  
Fax: +90 232 880 90 02



info@tpelectric.com.tr



Kemalpaşa O.S.B. 600 Sk. No:364  
35730 Kemalpaşa - İZMİR / TÜRKİYE